

ROOTS

Blowers Compressors Exhausters

Roots TRI-NADO™ TM Truck-Mount, Tri-Lobe Vacuum Blowers

Frame 1125

The Roots TRI-NADO™ TM Truck-Mount, Tri-Lobe Vacuum Blowers have been redesigned to incorporate the latest technology for reduced noise and vibration. These features include:

- Cast-Foot Design for Reduced Vibration
- Stronger Construction for Minimum Noise and Vibration
- Progressive Chamber Design That Reduces Noise and Features Cooler Operation.

CASING - The casing is of one piece close-grained cast iron construction. The casing is heavily ribbed to prevent distortion under the most severe operating conditions and incorporates the Roots WHISPAIR™ feature for reduced pulsation, horsepower and noise levels.

IMPELLERS - The closed-end impellers are made from ductile iron with high tensile strength, and operate without liquid sealing or lubrication.

SHAFTS - The shafts are 3" diameter alloy steel forgings flange connected to the impeller body.



TIMING GEARS - The impellers are timed by a pair of alloy steel spur gears that operate in an oil bath.

BEARINGS - The impeller/shaft assemblies are supported at each end by antifriction bearings.

LUBRICATION - A patented jet spray oil slinger system provides lubrication to gears and bearings.

PERFORMANCE TABLE

Speed	6" HgVac		15" HgVac		21" HgVac		24" HgVac		27" HgVac		28" HgVac	
	CFM	BHP	CFM	BHP	CFM	BHP	CFM	BHP	CFM	BHP	CFM	BHP
750	1768	28	1376	69.1	962	96.7	526	110.7	Blank Off	124.3		
1200	3064	44	2672	110.5	2258	154.7	1822	176.8	508	198.9		
1400	3640	52	3248	128.9	2834	180.5	2398	206.3	1084	232.1		
1600	4216	59	3824	147.4	3410	206.3	2974	235.8	1660	265.3		
1800	4792	74.4	4400	170.9	3986	235.1	3550	267.3	2236	299.4	Blank Off	310
2000	5368	84.8	4976	191.2	4562	262.1	4126	297.5	2812	333	Blank Off	344

Note: Vacuum ratings based on inlet air at standard temperature of 68° F, discharge pressure of 30" Hg and specific gravity of 1.0.



Roots

TRI-NADO™ TM DIMENSIONS

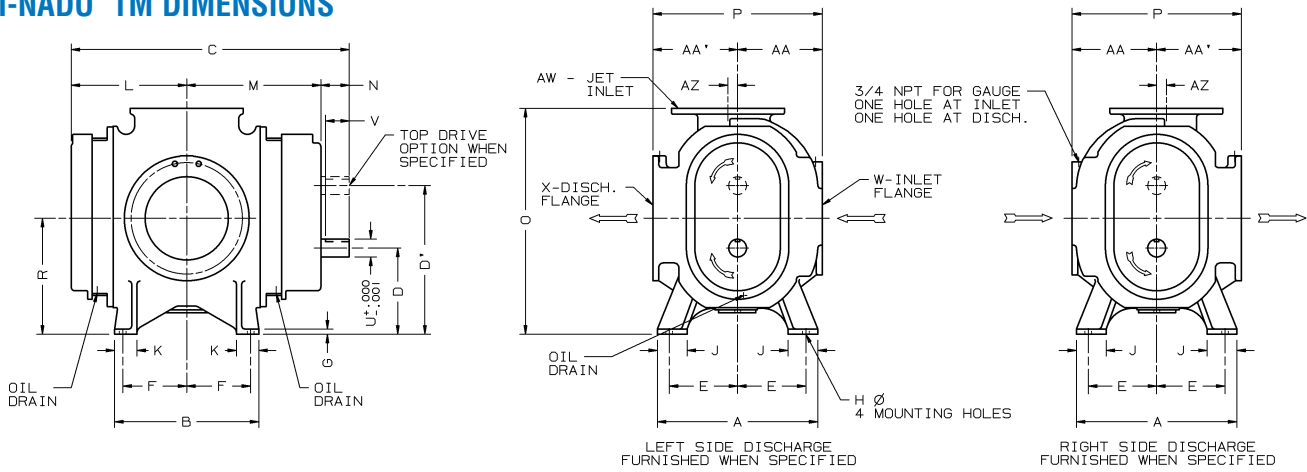

Frame	A	B	C	D	D ¹	E	F	G	H	J	K	L	M
TRI-NADO	27.00	24.25	46.79	14.50	25.00	11.50	10.75	.88	01.13	5.00	3.75	19.44	22.56
N	O	P	R	U	V	Keyway	W Flg	X Flg	AA	AA ¹	AW Flg	AZ	Approx. Net Wt.
4.79	38.00	28.50	19.50	3.000	4.00	.750 x .375	12	14	14.25	14.25	12	01.63	2500

NOTES:

1. Unless otherwise specified, dimensions are in inches.
2. Do not use for construction.

PRINCIPLE OF OPERATION

Shaded blue areas indicate air pressure variations from intake to atmosphere discharge.

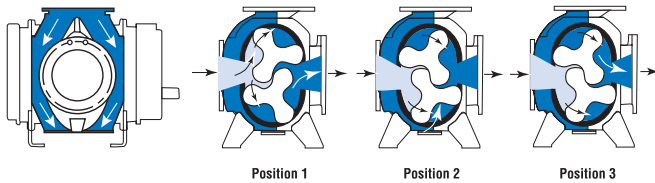

Position 1 - Incoming air is trapped between the impellers and the

case, producing a vacuum in the application system. Simultaneously, air is discharged (right) from the vacuum blower.

Position 2 - As the impeller passes the jet plenum, atmospheric air flows into the space between the impeller and the case. This cools the trapped air, aids impeller movement and reduces shock and power loss.

Position 3 - The trapped air is then moved to the discharge flange (right). Backflow is reduced, resulting in lower discharge noise relative to conventional rotary vacuum blowers.

TESTING

Each ROOTS rotary lobe vacuum blower is given a complete mechanical run at full speed and vacuum to ensure mechanical integrity and verify performance. The units are operated at maximum rated vacuum level for a minimum of one hour after temperatures have stabilized. Performance readings are recorded during the test, and each unit must meet vibration in three planes before being certified as acceptable.



S-8134B99
January 2006

**Dresser Roots
Headquarters**
16240 Port Northwest Drive
Houston, TX 77041
Toll Free (US): 1-877-363-7668
Ph: 832-590-2305
Toll Free (US) Fax: 1-877-357-7238
Fx: 832-590-2326

**Dresser Roots
Connersville Operation**
900 West Mount Street
Connersville, IN 47331
Ph: 765-827-9200
Fx: 765-827-9266

**Dresser Roots
Holmes Operation**
PO Box B7
Off St. Andrews Rd
Turnbridge, Huddersfield
England HD1 6RB
Ph: +44 (0) 1484 422 222
Fx: +44 (0) 1484 422 668

website: www.rootsblower.com • US email: roots@dresser.com • UK email: dmd_roots@dresser.co.uk