

ROOTS Blowers & Exhausters

DRESSER

TRINADO™ RANGE

POSITIVE DISPLACEMENT AIR BLOWERS

Size N08 & N10

Design Features

- The Trinado™ range has been designed as a drop-in replacement for the XLP range of blowers/exhausters.
- High temperature bearings with conservative load carrying capacity ensure extended operating life.
- The impeller profiles are designed to give torsional stability and ensure maximum volumetric efficiency.
- Precision ground gears are designed to ensure smooth running and accurate timing of the impellers.
- Shaft strength is substantially increased with the use of keyless taper mounted gears.
- Taper mounting gears simplify and quicken assembly and disassembly.
- Improved casting arrangement increases flange rigidity allowing vertical airflow mounting with minimal cylinder deformation.
- Trinado™ blowers/exhausters are constructed with air gaps, thereby isolating the compression chamber from the drive end and gear end lubricants.
- A non-contact internal labyrinth arrangement helps prevent oil leaks and the need for any lip seals other than the drive shaft PTFE seal.

When used as an Exhauster

The Trinado™ range of exhausters are designed to work down to 500 mbar gauge suction at the air inlet to the machine. When working in a relatively clean environment, a standard machine will be quite adequate. When working in say a dust laden atmosphere, closed end impellers are recommended. Should the filtration system fail, closure plugs will reduce the risk of contaminant ingress to the impellers, resulting in a loss of dynamic balance.

User Benefits

- A combination of impeller profile and cylinder geometry reduces discharge pulsations into the pipeline.
- Delivered air will be oil free.
- Machines can be installed for either vertical or horizontal air flow by repositioning the mounting feet.
- Rigid cylinder and flange designs enable direct flange mounting to discharge silencers. Installation costs can be reduced by the versatility of mounting arrangements.



- In all but the most extreme cases, the generous diameter of the drive shaft permits the use of v-belt drives without the need for double, outer bearing arrangement.
- All machines are performance tested at our works prior to despatch.

Specification

Casing

- Manufactured from high grade cast iron.
- Flanges drilled generally in accordance with BS EN 1092-2 PN16

Impellers and Shafts

- Sizes N, 1 and 2 have integral, ductile iron shafts and body.
- Size 3 and 4 have ductile iron bodies with steel stub shafts.
- All sizes are dynamically balanced to close tolerances.

Bearings

- Oil lubricated at both drive and non-drive ends.
- High temperature bearings throughout.
- Positive location is achieved with spherical bearings at drive end.

Lubrication

- Both drive and gear end components are oil splash lubricated.
- Synthetic lubricants are recommended.

Direction of Rotation

- Standard machines have a left hand drive shaft, top inlet for vertical air flow and a bottom drive shaft, left hand inlet for horizontal air flow. Anti-clockwise rotation looking on blower shaft end.
- Non standard variations can be catered for on request.

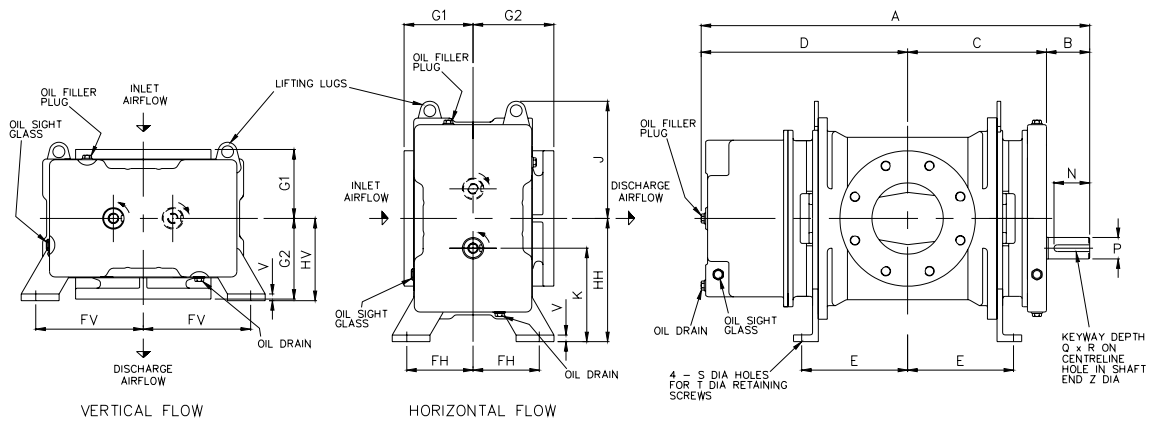

L Diameter bore

M Outside diameter

W Number of **X** diameter holes on **Y** pitch circle diameter 'Off Centres'

Inlet and outlet flanges drilled generally in accordance with BS EN 1092-2

Note: The standard arrangement is bottom shaft, anti-clockwise rotation for left to right air flow on horizontal flow machines. For vertical flow machines (top inlet), the standard arrangement is left hand shaft, anti-clockwise rotation. Non standard shaft arrangement (shown dotted) is available on request

Weight

Size	N08	N10
kg	175	127

Dimensions (mm)

Trinado Size	A	B	C	D	E	FH	HH	FV	HV	G1	G2	J	K	L	M	N	P	Q	R	S	T	V	W	X	Y	Z
N08	798	80	296	422	235	121	225	191	155	212	225	212	175	150	285	65	35.002/35.018	5	10	14	M12	14	8	M20	240	M12
N10	698	80	246	372	185	121	225	191	197	212	225	212	175	125	254	65	35.002/35.018	5	10	14	M12	14	8	M16	210	M12

Blower Performance

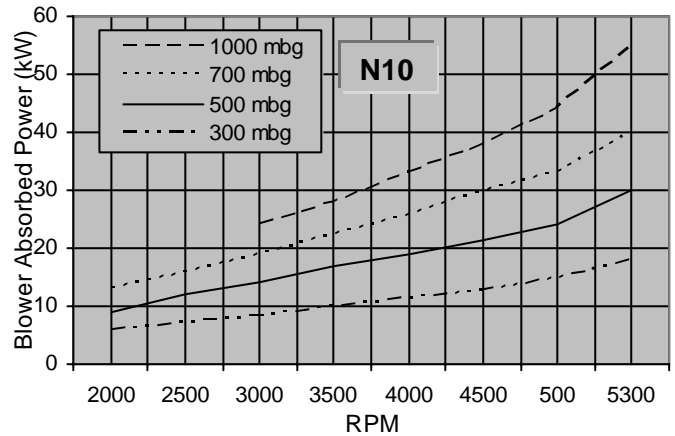
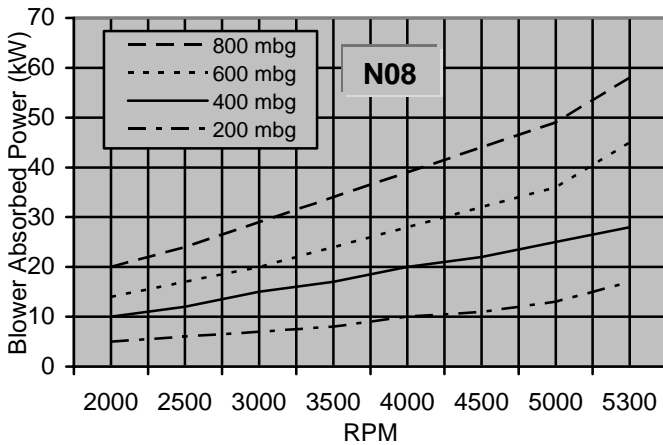
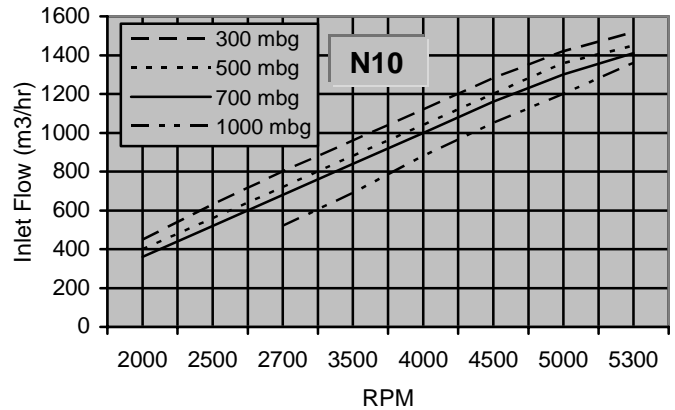
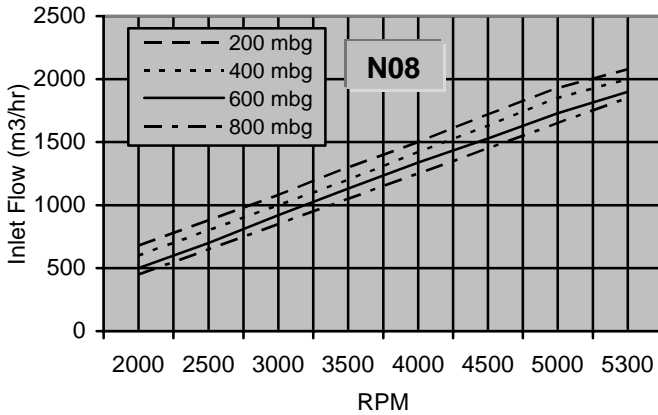

Inlet volumes are based on 15 °C and 1013 mbar



Roots

The original **ROOTS** Blower™

Following the Company's policy of constant development, we reserve the right to alter any detail specified or illustrated in this data sheet without notice and without incurring any obligation to provide such modifications on machines previously delivered. The inclusion of any item of equipment does not imply that it is a standard component on the product featured.

Dresser Roots - Holmes Operation

PO Box B7, Off St Andrews Road, Huddersfield, HD1 6RB, England

Tel: +44 (0)1484 422222 Fax: +44 (0)1484 423429

E-mail: dmd_roots@dresser.co.uk / www.rootsblower.com

TriN/01.08.05